

# WEENIE WAGON HOT DOG CART

Features

Details

Specs

Schematics



## FEATURES

- DOUBLE-RACK GRILL
- DOUBLE STEAM TABLE
- 4 STEAM PANS w/LIDS
- 4 SINKS
- HOT & COLD WATER
- 2 SWIVEL FAUCETS
- 12V WATER PUMP
- WATER HEATER
- 5 GAL FRESH WATER TANK
- 7 GAL WASTE WATER TANK
- INSULATED BEVERAGE BIN (240 cans)
- CUSTOMER PREP SHELF
- INTERIOR STORAGE
- ACCESS DOOR w/KEY
- 4 WINDOWS
- ADJUSTABLE AWNING
- CEILING VENT
- 1500 LBS. WHEEL LEVELING JACK
- REMOVABLE TOW BAR
- 2" BALL COUPLER
- OPERATOR MANUAL
- SCHEMATICS (for Health Dept. review)
- ONE YEAR WARRANTY

**"Going places!"**

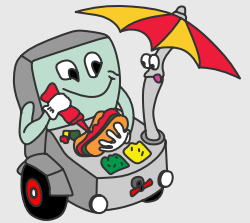

**Hot Dog  
Cart Company**

4497 Springbrook Rd.  
Jackson, MI 49201



**734-507-1212**

## DETAILS/DESCRIPTIONS

### GRILL

The Weenie Wagon hot dog cart is equipped with a double-rack, 55,000 BTU grill with four independent burners and ample cooking space. The drip tray is located below and sufficient to hold grease for months, minimizing the need for frequent cleaning. Due to the popularity of grilling as opposed to steaming, this is an attractive feature.

### STEAM TABLE

The steam table on the Weenie Wagon hot dog cart consists of two, large cast iron burners with individual shut off valves. The steam table accommodates four 1/2 size pans. The pans are 6" deep and come with solid lids and three separator bars. You can steam, boil or warm up food items of your choice (hot dogs, buns, chili, etc.). Alternative configurations are available. Pans are easily removable for cleaning and maintenance. All pans and lids are NSF approved and listed.

### SINKS

The hot dog cart has four sinks and two swivel faucets with hot and cold water for handwashing, rinsing, washing and sanitizing. Water pressure is provided by a 12V water pump. Water is heated with an instant propane water heater.

### WATER STORAGE

The Weenie Wagon hot dog cart has one 5 gal. fresh water tank and a 7 gal. waste water tank. Capacity can be increased.

### BEVERAGE BIN

The Weenie Wagon hot dog cart is equipped with an insulated stainless steel beverage bin with a hinged lid and an individual drain. It has a 240 can capacity.

### DRY STORAGE

The Weenie Wagon has ample interior floor space that can be used to store dry goods and food items.

### HEATING SOURCE

The two burners on the steam table, the grill, and the water heater run on propane, which is stored neatly in a double cylinder hold-down rack located inside the cart. It holds two 20 lb. propane tanks (not incl.), reducing the need for replacement during high-volume events.

### WINDOWS

The Weenie Wagon hot dog cart has four, large customer service windows for fast and easy service. Optional screens are available if required. The sliding windows have lockable latches for security.

### CONDIMENT EXTENSION (ADDITIONAL)

The condiment extension on the hot dog cart features five condiment pans with slotted lids. It is located on the opposite side of the vendor, ensuring efficient customer flow.

### AWNING/ENCLOSURE

The Weenie Genie hot dog cart is equipped with hinged awnings to provide customers cover from the rain or the sun. The awning has lockable latches for security.

### CEILING VENT

The Weenie Wagon hot dog cart has ceiling vent to circulate air and to keep the interior ventilated without compromising security. The vent cover opens and closes with a hand-operated crank.

### ACCESS DOOR

Entrance to the Weenie Wagon hot dog cart is located on the side of the cart and is equipped with a key lock for security.

### SHELVES

The Weenie Wagon hot dog cart has an exterior customer shelf that extends the length of the cart. Additional shelving available upon request.

### TRAILER

The hot dog cart rests on a D.O.T.-approved heavy-duty trailer (title available) with baked enamel finished. The leaf spring suspension system allows you to tow it at freeway speeds with safety. The tire size is 4.8" x 12" standard.

### TOWING BAR

The tow bar hitch on the hot dog cart is removable, increasing the approachability of your cart while minimizing safety issues. It is equipped with a 2" ball coupler with two safety chains.

### LIGHTS

The lights on the hot dog cart are tail, stop, signals and hazards. The wiring harness for the lights is male. The lights come with a license plate holder.

### WHEEL LEVELING JACK

The hot dog cart comes with a 1500 lb. capacity swing-back trailer jack. Just fold it back and away when ready for transport. The trailer jack has a side crank handle to level it.

# SPECIFICATIONS

CART BODY	L 90" x W 40.5" x H 76" 18-gauge stainless steel construction Diamond-plate floor
TRAILER	L 106" x 52.5" x H 89.5" 2" ball coupler 2 safety chains
SUSPENSION	Highway rated 1/2 ton leaf suspension
TIRES	4.8" x 12" standard
ELECTRICAL	Tail, stop, signal, hazard lights Male wiring harness installed
LEVELING JACK	1500 LB wheel leveling jack
SINKS	4 sinks Wash, rinse, sanitize, handwashing
FRESH WATER TANK	5 GAL Instant propane water heater
WASTE WATER TANK	7 GAL
COLD STORAGE	Insulated beverage bin w/drain 240 can capacity

DRY STORAGE	Interior floor area
STEAM PANS	4 - 1/2 size (10"x12"x6")   4 lids 3 seperator bars 5 condiment pans   5 slotted lids
BURNERS	2 - 19,000 BTU burners w/adjustable controls (steam table)
GRILL	4 burners 55,000 BTU Gas Double-rack
PROPANE	Double-cylinder hold-down rack 2 - 20 LB propane tanks (not incl.) Two-stage regulator
CIRCULATION	4 windows Ceiling vent
AWNING	Steel, bi-color
STANDARD FEATURES	Hot and cold running water 2 swivel faucets
ADD'L EQUIPMENT OPTIONS	Add'l awning colors available Increased water storage Add'l shelving Condiment extension

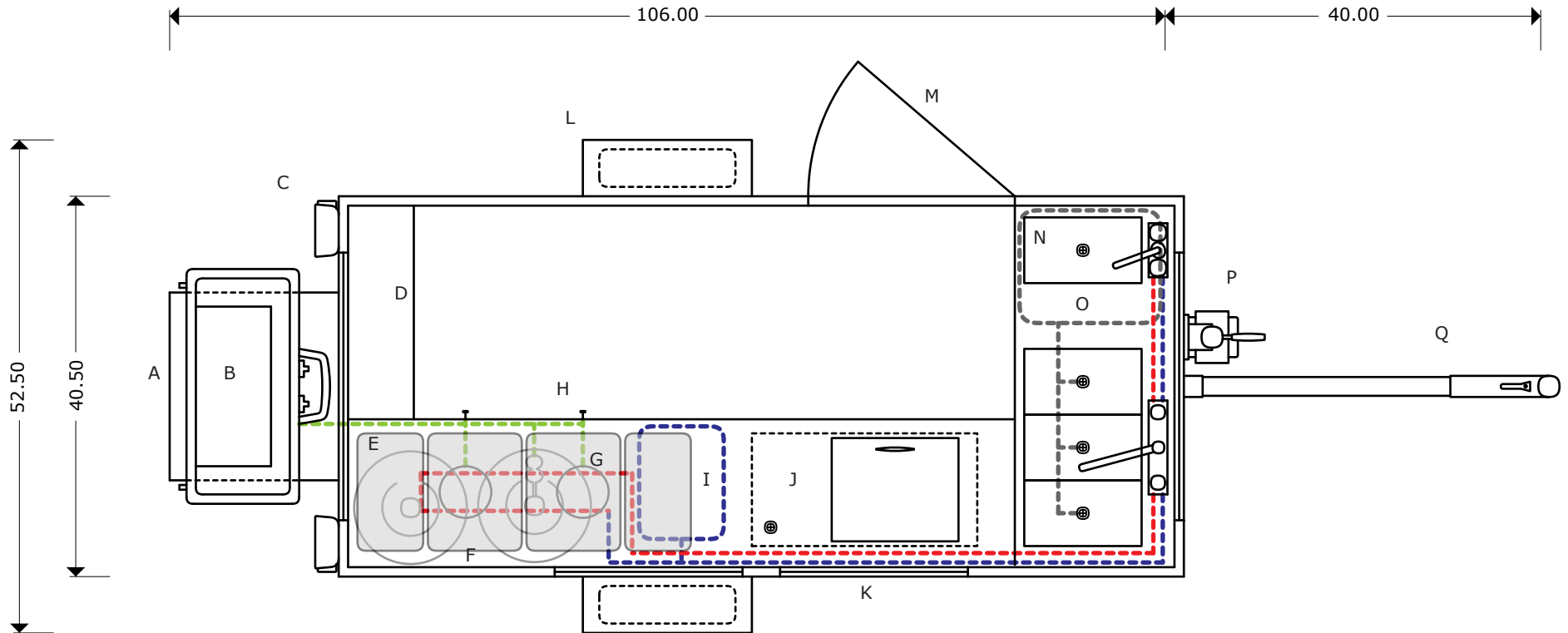

- A-GRILL SHELF
- B-GRILL
- C-TAIL LIGHT
- D-PREP SHELF
- E-STEAM PAN
- F-20 LB PROPANE TANKS
- G-BURNER
- H-BURNER CONTROL
- I-5 GAL FRESH WATER TANK

- J-BEVERAGE BIN
- K-WINDOW
- L-FENDER/TIRE
- M-DOOR
- N-SINK
- O-7 GAL WASTE WATER TAN
- P-WHEEL LEVELING JACK
- Q-TOW BAR w/BALL COUPLER

- Cold water line
- Hot water line
- Gas line
- Wastewater line

# SCHEMATICS

# WEENIE WAGON

Left Side View

Hot Dog  
Cart Company

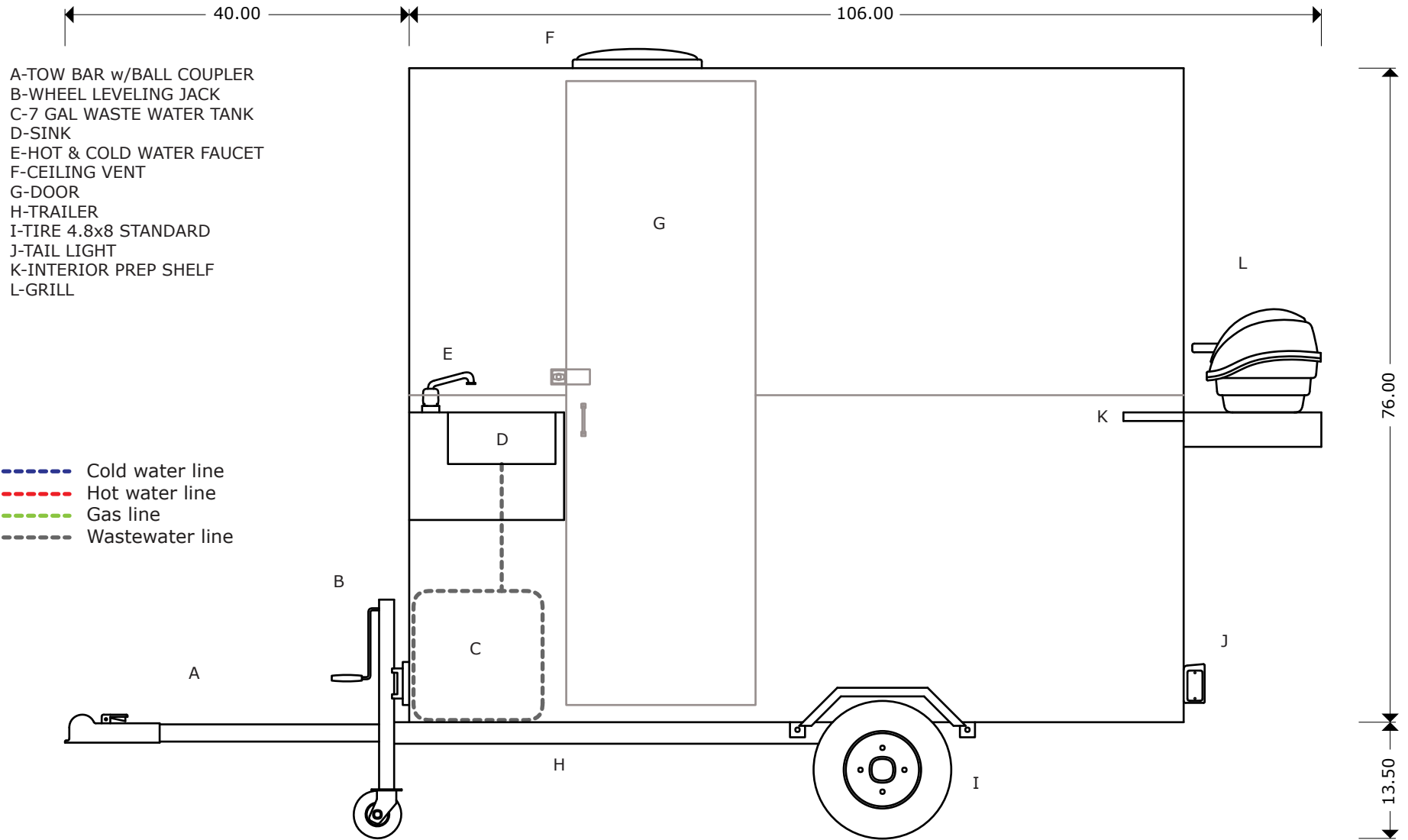

# SCHEMATICS

# WEENIE WAGON

Right Side View

Hot Dog  
Cart Company

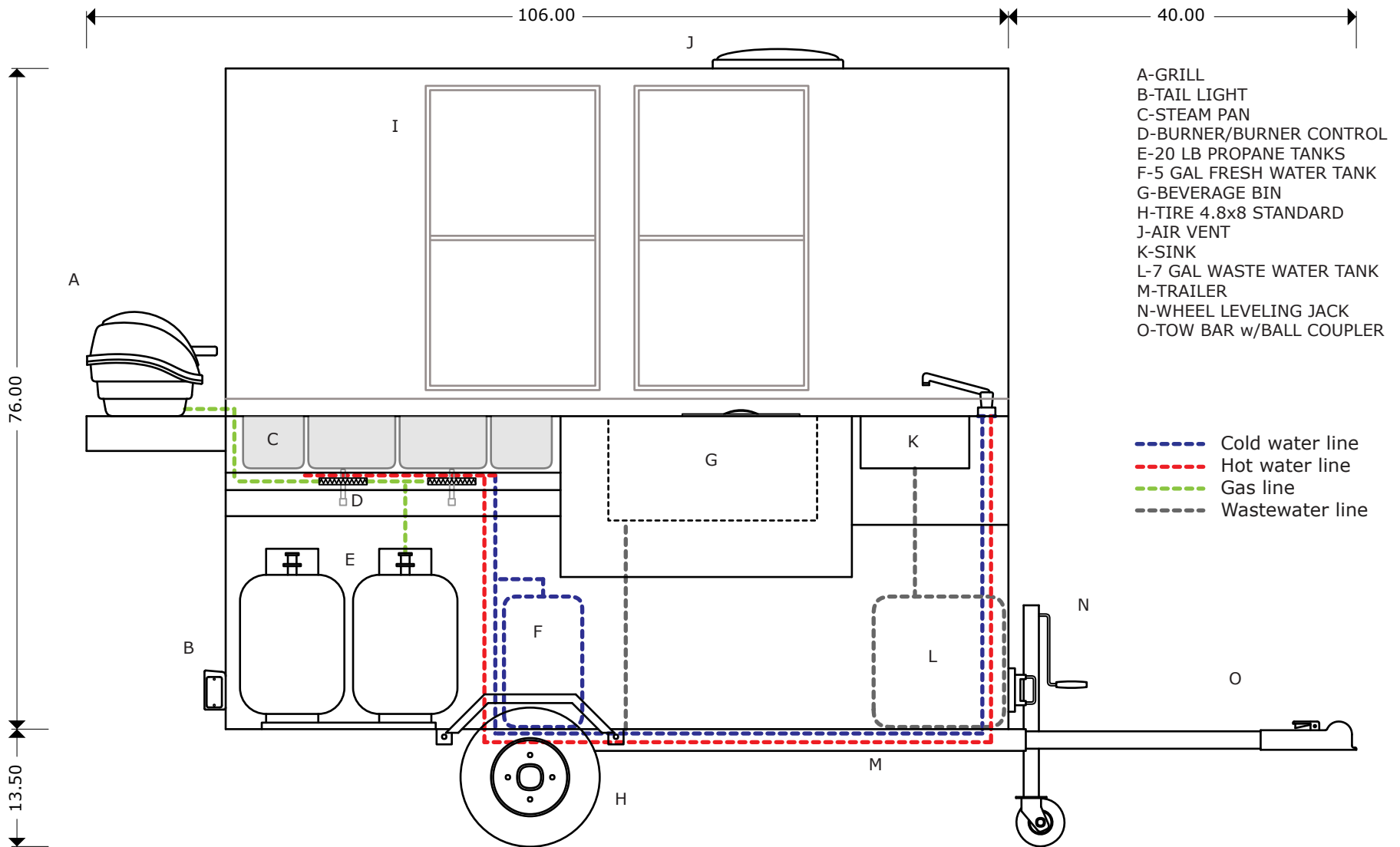

- A-GRILL
- B-TAIL LIGHT
- C-STEAM PAN
- D-BURNER/BURNER CONTROL
- E-20 LB PROPANE TANKS
- F-5 GAL FRESH WATER TANK
- G-BEVERAGE BIN
- H-TIRE 4.8x8 STANDARD
- J-AIR VENT
- K-SINK
- L-7 GAL WASTE WATER TANK
- M-TRAILER
- N-WHEEL LEVELING JACK
- O-TOW BAR w/BALL COUPLER

- Cold water line
- Hot water line
- Gas line
- Wastewater line