

# LIGHTNING BOLT GRILL HOT DOG CART

Features

Details

Specs

Schematics



## FEATURES

- DOUBLE-DECKER GRILL
- 2 BURNER STEAM TABLE
- 4 1/2 SIZE STEAM PANS
- 6 1/6 SIZE PANS
- 2 ROLL TOP COVERS
- HOT AND COLD WATER
- 4 SINKS
- 2 SWIVEL FAUCETS
- 12V WATER PUMP
- 5 GAL. FRESH WATER TANK
- 7 GAL. WASTE WATER TANK
- BI-LEVEL BREAD BOX
- VENDOR PREP SHELF
- CUSTOMER PREP SHELF
- INTERIOR STORAGE
- INTERIOR PROPANE COMPARTMENT
- 9 FT. MARKET UMBRELLA
- WHEEL LEVELING JACK
- REMOVABLE TOW BAR
- 1 7/8" BALL COUPLER
- 2 SAFETY CHAINS
- OPERATOR MANUAL
- SCHEMATICS (for Health Dept. review)
- ONE YEAR WARRANTY

"Going places!"

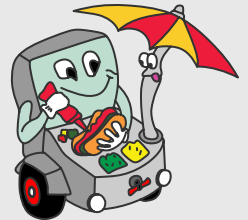

**Hot Dog  
Cart Company**

4497 Springbrook Rd.  
Jackson, MI 49201

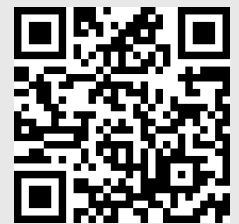

# 734-507-1212

## DETAILS/DESCRIPTIONS

### GRILL

The grill on the Lightning Bolt Grill hot dog cart is a double rack, 55,000 BTU grill with two burners. The drip tray is located below and sufficient to hold grease for months, minimizing the need for frequent cleaning. Due to the popularity of grilling as opposed to steaming, this is an attractive feature.

### STEAM TABLE

The steam table on the Lightning Bolt Grill hot dog cart consists of two large, cast iron burners with individual shut off valves. The steam table accommodates four 1/2-size pans with solid lids and six 1/6-size pans with slotted lids. Additional configurations are available. You can steam, boil or warm up food items of your choice (hot dogs, buns, chili, cheese etc.). Pans are easily removeable for cleaning and maintenance. All pans and lids are NSF approved and listed.

### SINKS

The hot dog cart has four sinks and two swivel faucets with hot and cold water for handwashing, rinsing, washing and sanitizing. Three of the sinks are full size (10" x 12") and the fourth is 1/4 size (6" x 6").

### WATER STORAGE

The hot dog cart has a 5 gal. fresh water tank and a 7 gal. waste water tank. Water pressure is provided by a 12V water pump.

### BEVERAGE BIN

N/A

### MEAT BIN

N/A

### DRY STORAGE

The Lightning Bolt Grill hot dog cart features a bi-level bread box behind two sliding, stainless steel doors and is sealed (so you don't need to remove anything in case of rain). The lower-level of the bread box accommodates 30 bags (a total of 360 units) of buns. The upper level is ideal for storing extra dry goods such as foil, napkins, paper bags, etc.

### HEATING SOURCE

The two burners of the Lightning Bolt hot dog cart run on propane, which is stored neatly in an interior compartment accessed by a hinged door with a safety latch. It accommodates two, 20 lb. propane tanks (not included) ensuring you never run out during an event. The propane line has a dual stage regulator.

### SHELVING

A conveniently located, vendor-side prep shelf extends the width of the cart. A customer prep shelf is located on the opposite side of the hot dog cart, ensuring efficient customer flow during high-traffic events.

### UMBRELLA STAND

The umbrella stand located in the center of the cart holds a 9 ft. market umbrella, providing extensive shade. This type of umbrella eliminates the need for cleaning as it is easy and inexpensive to replace.

### TRAILER

The hot dog cart rests on a D.O.T.-approved heavy-duty trailer (title available) with baked enamel finished. The leaf spring suspension system allows you to tow it at freeway speeds with safety. The tire size is 4.8" x 8" standard.

### TOWING BAR

The tow bar on the hot dog cart is removable, increasing the approachability of the cart and reducing potential safety issues. It is equipped with a 1 7/8" ball coupler and two safety chains. Optional 2" ball coupler available.

### LIGHTS

The lights on the hot dog cart are tail, stop, signals and hazards. The wiring harness for the lights is male. The lights come with a license plate holder.

### WHEEL LEVELING JACK

Keep your hot dog cart on the level with this easy-to-use 1000 lb. capacity swing-back trailer jack. With the swing-back style there's no need to remove the jack when hauling the hot dog cart, just fold it back and away. The trailer jack has a side crank handle to level it.

# SPECIFICATIONS

CART BODY	L 86.5" x W 56.5" x H 44.5" 18-gauge stainless steel
TRAILER	L 92.5" x W 52.5" x H 58" 1 7/8" ball coupler 2 safety chains
SUSPENSION	Highway rated 1/2 ton leaf suspension
TIRES	4.8" x 8" standard
ELECTRICAL	Tail, stop, signal, hazards Male wiring harness installed Water pump (12V)
LEVELING JACK	Wheel leveling jack
SINKS	4 sinks Wash, rinse, sanitize, handwashing
FRESH WATER TANK	5 GAL
WASTE WATER TANK	7 GAL
COLD STORAGE	None

DRY STORAGE	Bi-level bread box Interior propane compartment
STEAM PANS	4 - 1/2 size (10"x12"x6") 6 - 1/6 size (6"x6"x4") 4 solid lids/6 slotted lids Separator bars *Alternative config. avail.
GRILL	2 - 55,000 BTU burners Double-rack Gas
BURNERS	2 - 19,000 BTU burners w/adjust- able controls (steam table)
PROPANE	2 - 20 LB propane tanks (not incl.)
PROPANE REGULATOR	Two-stage regulator
STANDARD FEATURES	Hot and cold running water Swivel faucets
ADD'L EQUIPMENT OPTIONS	9 ft. market umbrella 2" ball coupler Alternative steam pan config.

# SCHEMATICS

# LIGHTNING BOLT GRILL

Top View

Hot Dog  
Cart Company

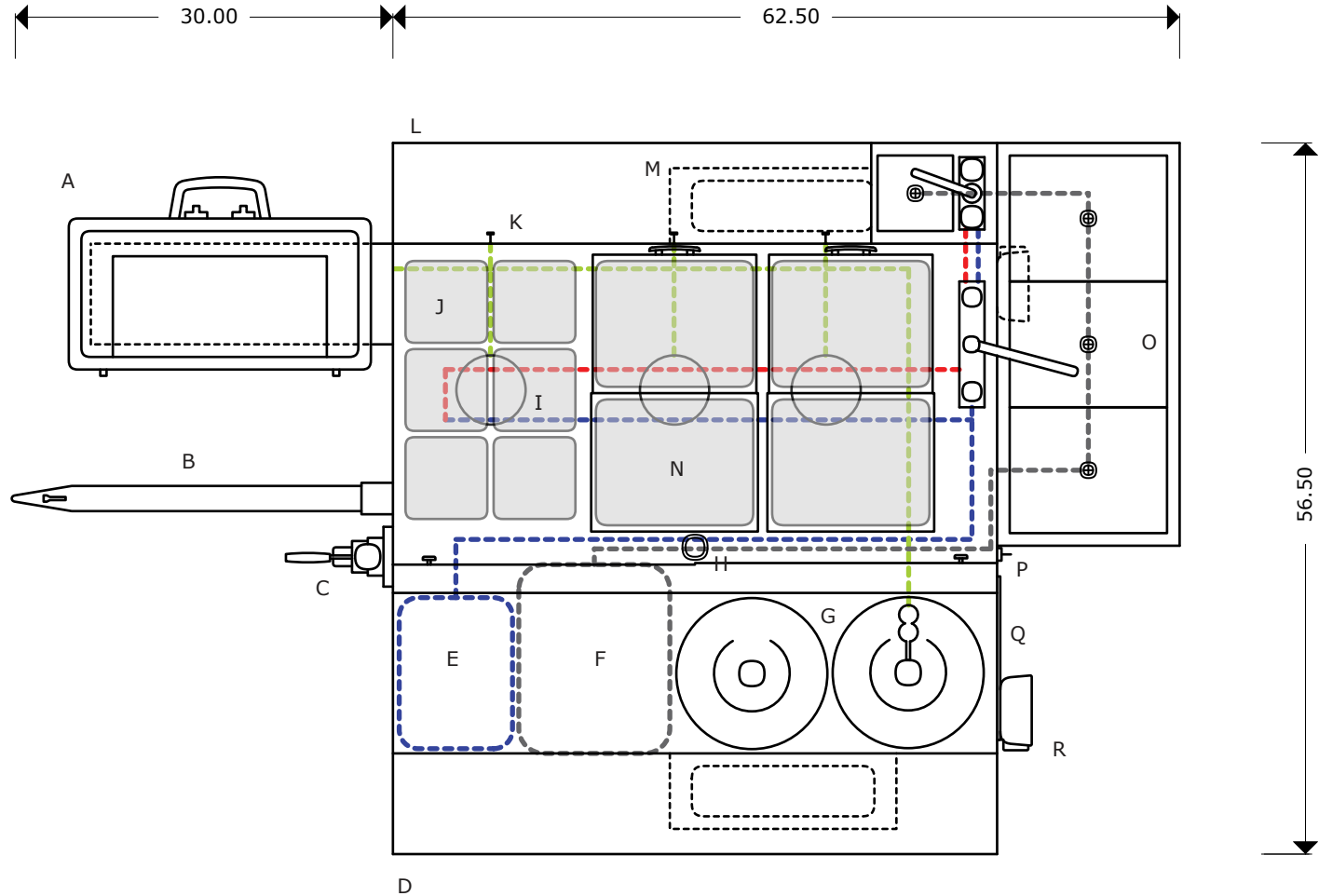

# SCHEMATICS

# LIGHTNING BOLT GRILL

Left Side View

Hot Dog  
Cart Company

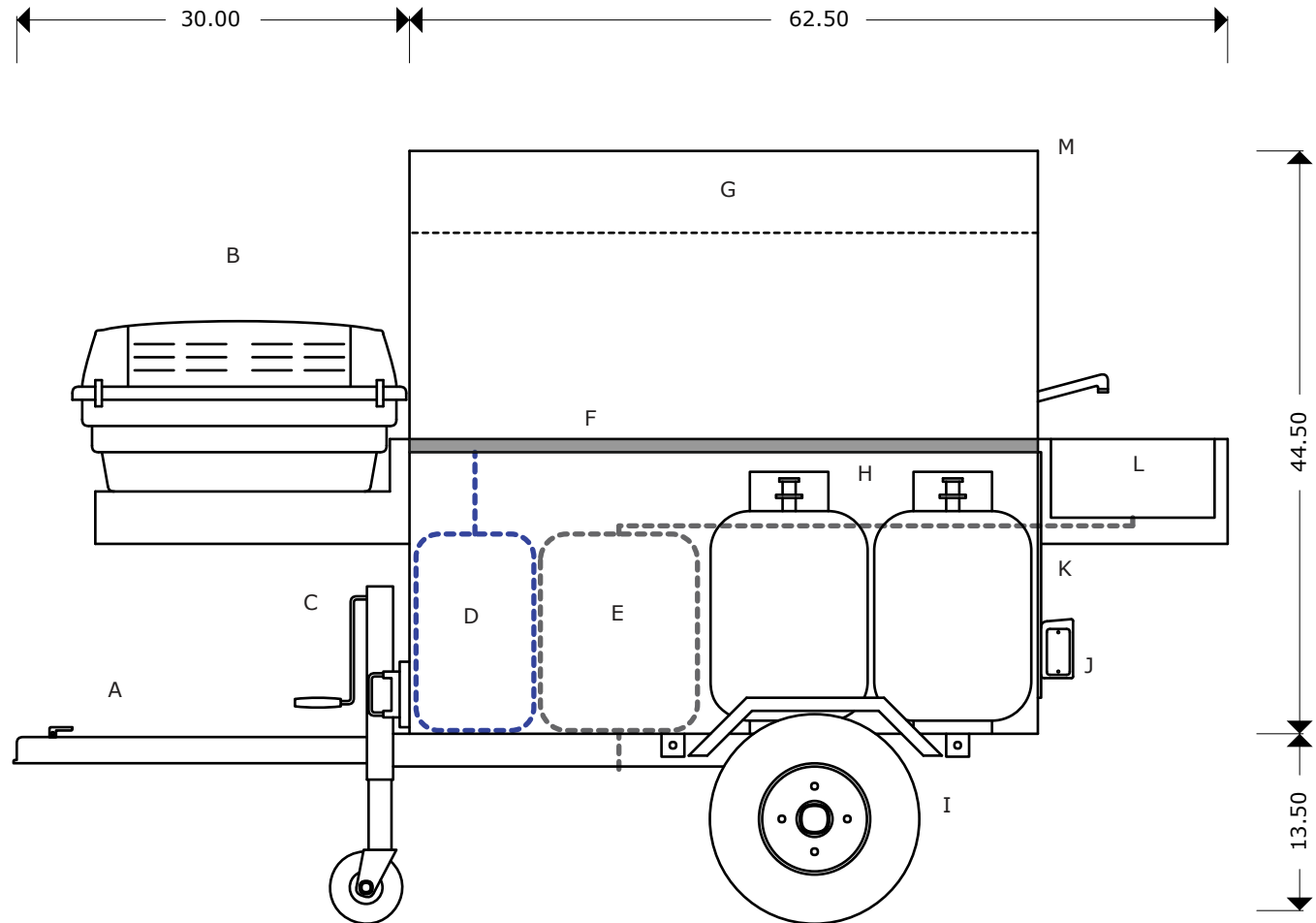

# SCHEMATICS

# LIGHTNING BOLT GRILL

Right Side View

# Hot Dog Cart Company

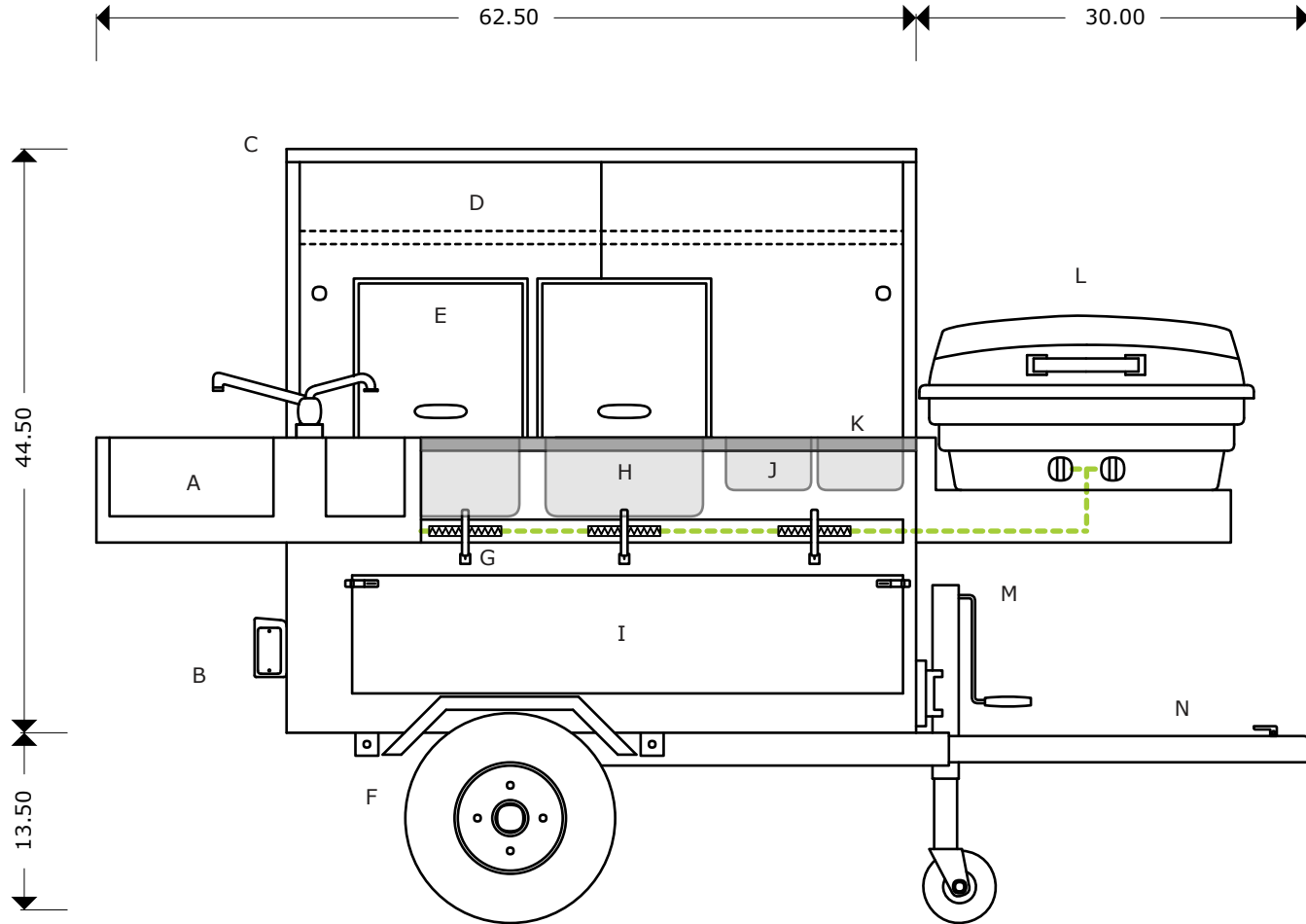

- A-SINK
- B-TAIL LIGHT
- C-BI-LEVEL BREADBOX
- D-INTERIOR SHELF
- E-ROLL TOP COVER
- F-TIRE/FENDER
- G-BURNER/BURNER CONTROL
- H-STEAM PAN
- I-SIDE ACCESS DOOR
- J-STEAM PAN
- K-VENDOR PREP SHELF
- L-DOUBLE-RACK GRILL
- M-WHEEL LEVELING JACK
- N-TOW BAR w/BALL COUPLER

- - - - - Cold water line
- - - - - Hot water line
- - - - - Gas line
- - - - - Wastewater line