

CALIFORNIA HOT DOG CART

Features

Details

Specs

Schematics



\$8,699



FEATURES

- TRIPLE STEAM TABLE
- 2 ROLL TOP COVERS
- 4 - 1/2 sz. STEAM PANS
- 6 - 1/6 sz. STEAM PANS
- REFRIGERATION UNIT
- HOT & COLD WATER
- 4 JUMBO SINKS
- 4 SWIVEL FAUCETS
- 12V WATER PUMP
- WATER HEATER
- 20 GAL FRESH WATER TANK
- 36 GAL WASTE WATER TANK
- INSULATED BEVERAGE BIN (144 can capacity)
- MALE OUTLET
- 2 ELECTRICAL OUTLETS
- INTERIOR STORAGE
- 2 UMBRELLA STANDS
- 1500 LBS. WHEEL LEVELING JACK
- REMOVABLE TOW BAR
- 1 7/8" BALL COUPLER
- OPERATOR MANUAL
- SCHEMATICS (for Health Dept. review)
- ONE YEAR WARRANTY

"Going places!"

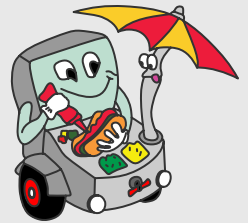

**Hot Dog
Cart Company**

4497 Springbrook Rd.
Jackson, MI 49201



734-507-1212

DETAILS/DESCRIPTIONS

STEAM TABLE

The steam table on the California hot dog cart consists of three, large cast iron burners with individual shut off valves. The steam table has two roll top covers with four 1/2 size pans. The third section of the steam table has six 1/6 size steam pans with solid lids. Alternative configurations are available. Pans are easily removable for cleaning and maintenance. All pans and lids are NSF approved and listed.

SINKS

The California hot dog cart has three ware washing sinks with hot and cold water. Each ware washing sink is large enough to accommodate the largest utensil. Ware washing sinks are 12" x 12" x 10". Each ware washing sink is equipped with a mixing swivel faucet capable of providing hot water at a minimum of 120 degrees Fahrenheit and cold water at 99 degrees Fahrenheit or less as required by law. The hand washing sink is separated from the ware washing sinks by an 8" high metal splashguard.

The hand washing sink is 12" x 9" x 10". The hand washing sink is equipped with a mixing swivel faucet capable of providing hot water at a minimum of 120 degrees Fahrenheit and cold water at 99 degrees Fahrenheit or less as required by law.

WATER SYSTEM

Water pressure is provided by an electrical water pump (12V) capable of delivering water at a minimum of 1 gal./min. A 4 gal. water heater is connected to the fresh water tank and heats water a min. of 90F. The water pump is activated by an external switch.

WATER STORAGE

The California hot dog cart is equipped with four 5 gal. fresh water tanks, fulfilling the 5 gal. min. required for hand washing and the 15 gal. min required for ware washing and food preparation. The waste water tank has a 36 gal. capacity and has an air vent water flow to prevent flooding of the interior of the cart. Additionally, it has a discharge valve to facilitate complete drainage.

BEVERAGE BIN

The California hot dog cart is equipped with an insulated stainless steel beverage bin with a hinged lid and an individual drain. It has a 144 can capacity and is easily accessible to both vendors and customers.

DRY STORAGE

There are three interior storage compartments. The area at the front is allocated to propane storage. The three areas on the vendor side are ideal for storing extra food items or dry goods. Each compartment has a hinged door with a safety latch.

ELECTRICAL

The California hot dog cart has a male outlet located at the back of the cart for drawing power from external sources. In addition, there are two electrical outlets.

REFRIGERATOR

The cart is equipped with an electrical refrigeration unit to store perishable food items.

HEATING SOURCE

The three burners on the steam table run on propane, which is stored neatly in a double cylinder hold-down rack located inside the cart. It holds two 20 lb. propane tanks (not incl.), reducing the need for replacement during high-volume events.

UMBRELLAS STANDS

The California hot dog cart features two umbrella holders on each end of the cart. They hold two 9 ft. market umbrellas available in a variety of colors. This type of umbrella eliminates the need for cleaning as it is easy and inexpensive to replace.

TRAILER

The hot dog cart rests on a D.O.T.-approved heavy-duty trailer (title available) with baked enamel finished. The leaf spring suspension system allows you to tow it at freeway speeds with safety. The tire size is 4.8" x 8" standard.

TOWING BAR

The tow bar hitch on the hot dog cart is removable, increasing the approachability of your cart while minimizing safety issues. It is equipped with a 1 7/8" ball coupler with two safety chains. Optional 2" ball coupler available.

LIGHTS

The lights on the hot dog cart are tail, stop, signals and hazards. The wiring harness for the lights is male. The lights come with a license plate holder.

WHEEL LEVELING JACK

The hot dog cart comes with a 1500 lb. capacity swing-back trailer jack. Just fold it back and away when ready for transport. The trailer jack has a side crank handle to level it.

SPECIFICATIONS

| | |
|------------------|---|
| CART BODY | L 96" x W 48" x H 38" 18-gauge stainless steel construction |
| TRAILER | L 136" x 60" x H 51.5" 1 7/8" ball coupler 2 safety chains |
| SUSPENSION | Highway rated 1/2 ton leaf suspension |
| TIRES | 4.8" x 8" standard |
| ELECTRICAL | <ul style="list-style-type: none"> - Tail, stop, signal, hazard lights - Male wiring harness installed - Male outlet - 2 electrical outlets - Water pump (12V) - Water heater (4 GAL) |
| LEVELING JACK | 1500 LB wheel leveling jack |
| SINKS (4) | <ul style="list-style-type: none"> - Wash, rinse, sanitize (12"x12"x10") - Handwashing (12"x9"x10") |
| FRESH WATER TANK | 4-5 GAL tanks w/external intake valve |
| WASTE WATER TANK | 36 GAL Incl. discharge valve and air vent |

| | |
|-------------------------|--|
| DRY STORAGE | 3 interior compartments |
| STEAM PANS | 4 - 1/2 size (10"x12"x6") 4 lids 6 - 1/6 size (6"x6"x4") 6 lids Spillage pans |
| BURNERS | 3 - 19,000 BTU burners w/adjustable controls (steam table) |
| PROPANE | 2 - 20 LB propane tanks (not incl.) Double-cylinder hold-down rack |
| PROPANE REGULATOR | Two-stage regulator |
| STANDARD FEATURES | <ul style="list-style-type: none"> - Hot and cold running water - 4 swivel faucets |
| ADD'L EQUIPMENT OPTIONS | 9 ft. market umbrellas 2" ball coupler Alternative steam pan config. |

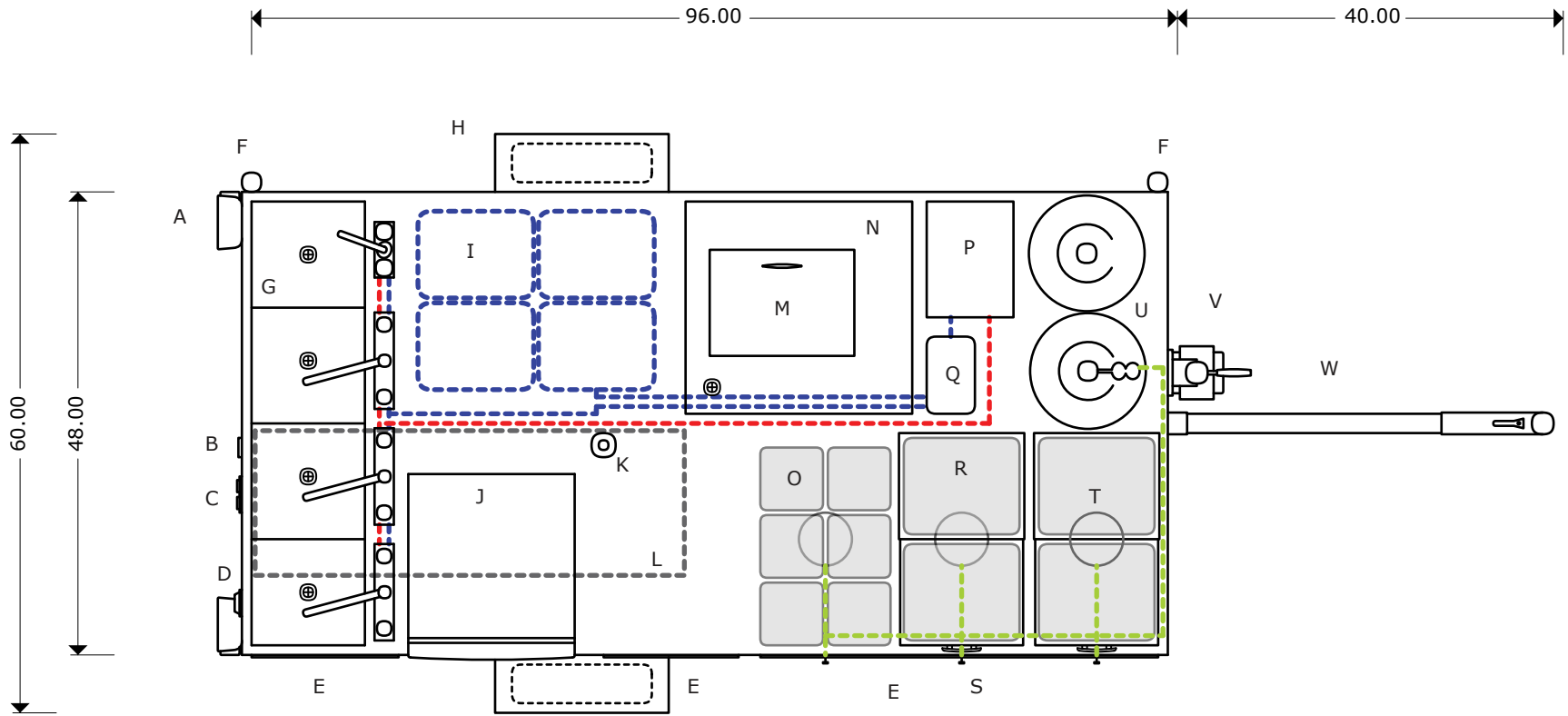

- A-TAIL LIGHT
- B-MALE OUTLET
- C-ELECTRICAL OUTLETS (2)
- D-WATER PUMP SWITCH
- E-SIDE ACCESS DOOR
- F-UMBRELLA STAND
- G-SINK
- H-TIRE/FENDER

- I-5 GAL FRESH WATER TANK
- J-REFRIGERATOR
- K-FRESH WATER TANK INLET
- L-30 GAL WASTE WATER TANK
- M-BEVERAGE BIN LID
- N-BEVERAGE BIN
- O-STEAM PAN (1/6 sz.)
- P-4 GAL WATER HEATER

- Q-WATER PUMP
- R-STEAM PAN (1/2 sz.)
- S-BURNER CONTROL
- T-BURNER
- U-20 LB PROPANE TANK(S)
- V-WHEEL LEVELING JACK
- W-TOW BAR w/BALL COUPLER

- Cold water line
- Hot water line
- Gas line
- Wastewater line

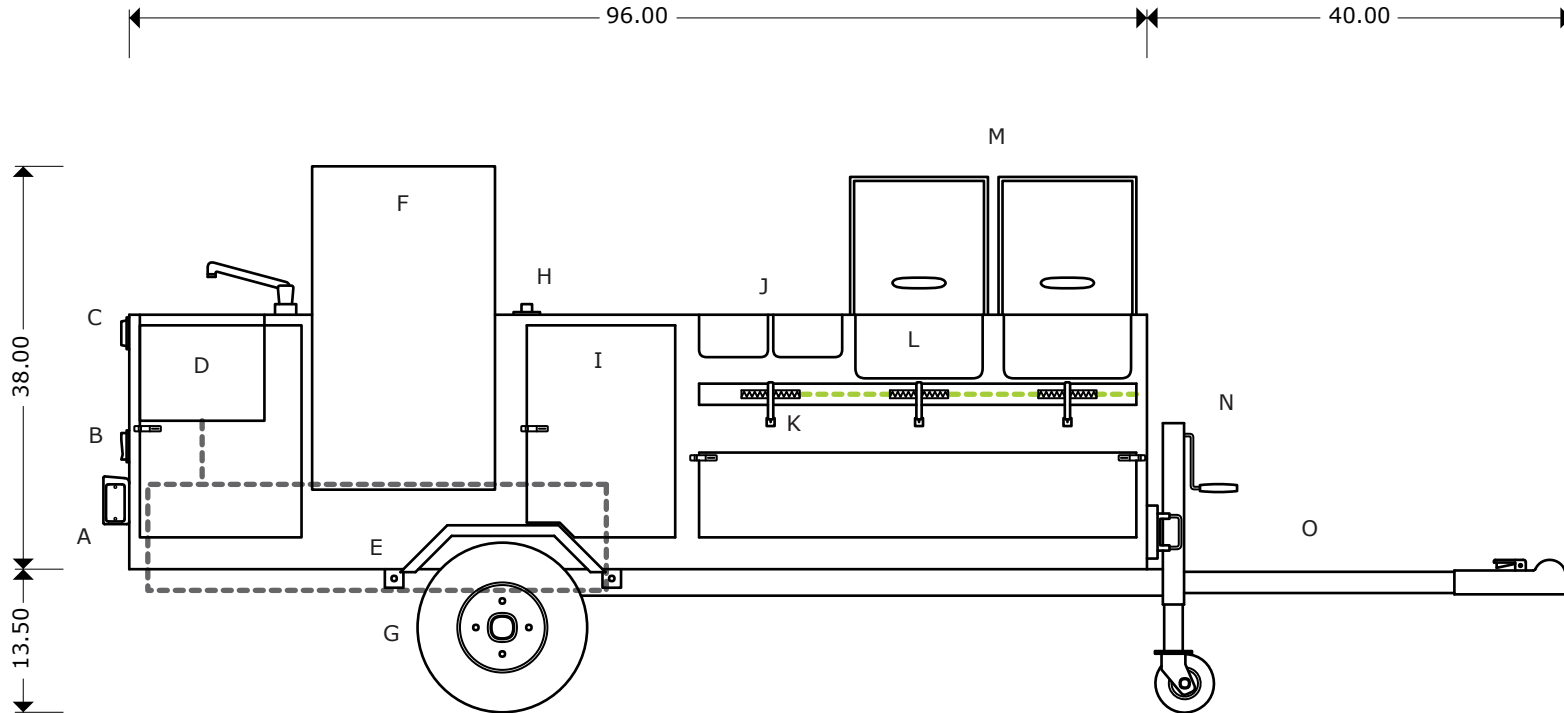

- A-TAIL LIGHT
- B-ELECTRICAL OUTLETS(2)
- C-WATER PUMP SWITCH
- D-SINK
- E-30 GAL WASTE WATER TANK
- F-REFRIGERATOR
- G-TIRE/FENDER
- H-FRESH WATER INTAKE VALVE

- I-SIDE ACCESS DOOR
- J-STEAM PANS (1/6 sz.)
- K-BURNER/BURNER CONTROL
- L-STEAM PAN (1/2 sz.)
- M-ROLL TOP COVERS
- N-WHEEL LEVELING JACK
- O-TOW BAR w/BALL COUPLER

- - - - Cold water line
- - - - Hot water line
- - - - Gas line
- - - - Wastewater line

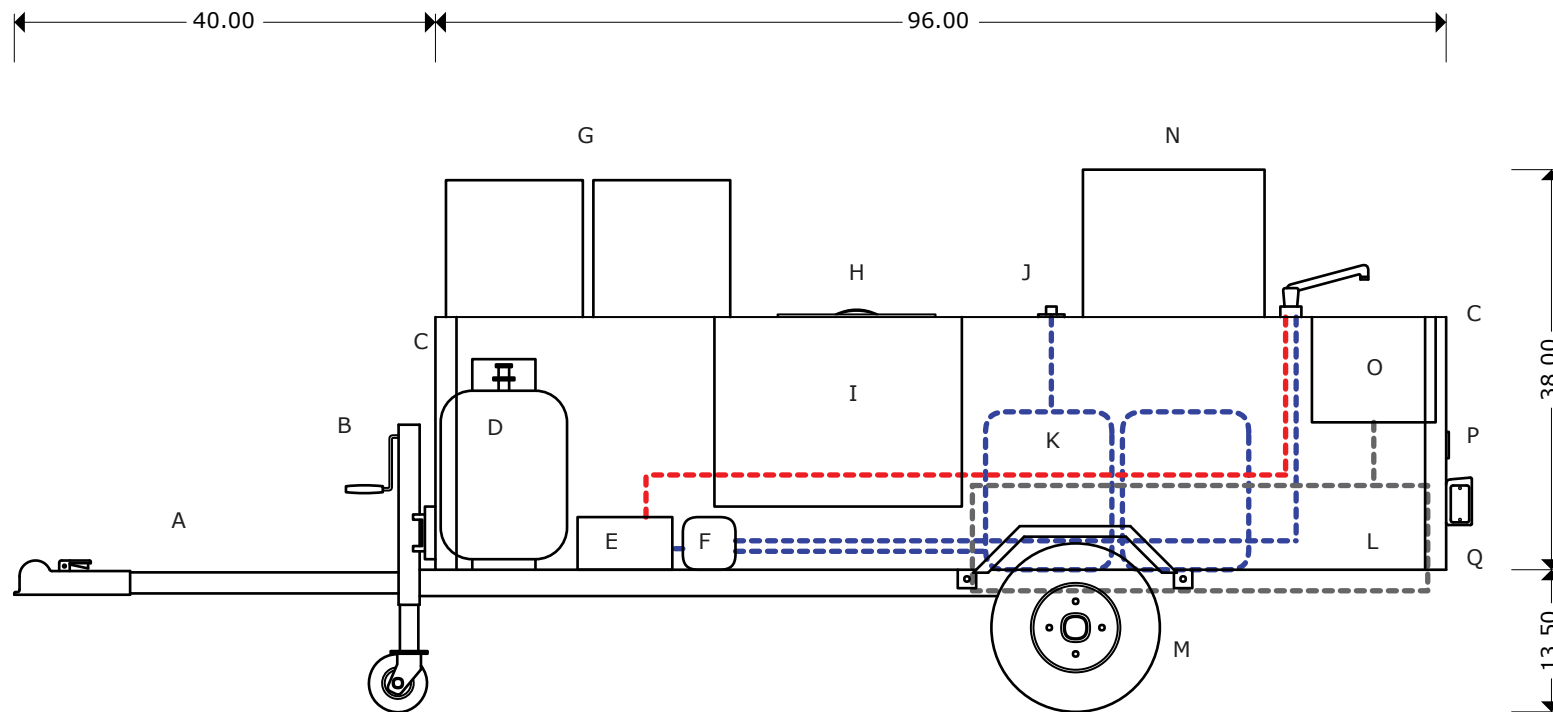

- A-TOW BAR w/BALL COUPLER
- B-WHEEL LEVELING JACK
- C-UMBRELLA STAND
- D-20 LB PROPANE TANK
- E-4 GAL WATER HEATER
- F-WATER PUMP
- G-ROLL TOP COVERS
- H-BEVERAGE BIN LID
- I-BEVERAGE BIN

- J-FRESH WATER INTAKE VALVE
- K-5 GAL FRESH WATER TANK
- L-30 GAL WASTE WATER TANK
- M-TIRE/FENDER
- N-REFRIGERATOR
- O-SINK
- P-MALE OUTLET
- Q-TAIL LIGHT

- - - - - Cold water line
- - - - - Hot water line
- - - - - Gas line
- - - - - Wastewater line